

KRONENBERG➤

Door Interlock DL(F)1MO

Operating Instructions

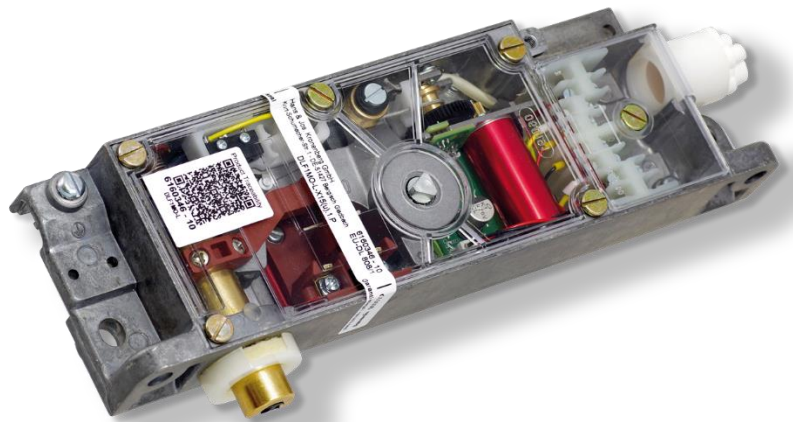

kronenberg-gmbh.de

Manufacturer

Hans & Jos. Kronenberg GmbH
D-51427 Bergisch Gladbach

Contact

Hans & Jos. Kronenberg GmbH
Kurt-Schumacher-Straße 1
D-51427 Bergisch Gladbach

T: +49 2204 / 207 -0

E: info@kronenberg-gmbh.de

W: kronenberg-gmbh.de

Document Information

Titel: kro_ba_dl(f)1mo_gb_2023, Stand: 11.10.2023

Legal Notices

© Hans & Jos. Kronenberg GmbH

All rights reserved.

All photos are property of Hans & Jos. Kronenberg GmbH.

This documentation may not be copied,

modified or translated into any other language in whole or in part.

Especially when using electronic systems, Hans & Jos. Kronenberg GmbH

have to agree to processing, duplication or storage of this documentation.

Inhalt

1	General information	4
2	Device dimensions	5
3	Function and initial operation	6
3.1	Mode of operation.....	6
3.2	Initial operation.....	6
3.3	Settings	6
3.4	Control	6
3.5	Closing ability	6
4	Maintenance	7
5	Electrical connection	7
5.1	Connection plan	7
6	Technical information	8
6.1	Operating directions	8
6.2	Customary positions	8
6.3	Technical data	8
7	Fault correction.....	9
7.1	Diagnosis at disruption in operation.....	9

1 General information

The conditions, notices and drawings contained in the EU type approval certificates EU-DL 807-2 and EU-DL 808-2 are part of the operating instructions. Therein are specified amongst others:

- description of functions
- installation conditions
- dimensions and variants

The operating instructions must always be kept in a legible condition and accessible.

Target group

All operations described in these operating instructions may only be carried out by trained personnel who are authorized by the operator of the installation. Only install and put the device into operation if you have read and understood the operating instructions and if you are familiar with the applicable regulations of occupational safety and accident prevention.

Intended use

The door interlock described here was developed to take over safety-relevant functions as part of a complete installation or machine. It is within the responsibility of the manufacturer of an installation or a machine to ensure the correct overall function. The door interlock may only be used in accordance with these operating instructions and in the versions described in the corresponding test certificates.

General safety instructions

The safety notes of the operating instructions as well as country-specific installation, safety and accident prevention instructions must be observed.

For further technical information please refer to our catalogues resp. our homepage kronenberg-gmbh.de.

Warning of misuse

In case of improper, unintended use or manipulation dangers to persons or damages at parts of the machines or installations can not be excluded.

Disclaimer

We will not be liable for damages and malfunctions caused by assembly faults or by non-observance of these operating instructions. Any further liability of the manufacturer is excluded for defects resulting from the use of spare parts or accessories which are not approved by the manufacturer.

Any unauthorized repairs, modifications and alterations are not permitted for safety reasons, exclude any liability of the manufacturer for any resulting damages and lead to the loss of the approval.

2 Device dimensions

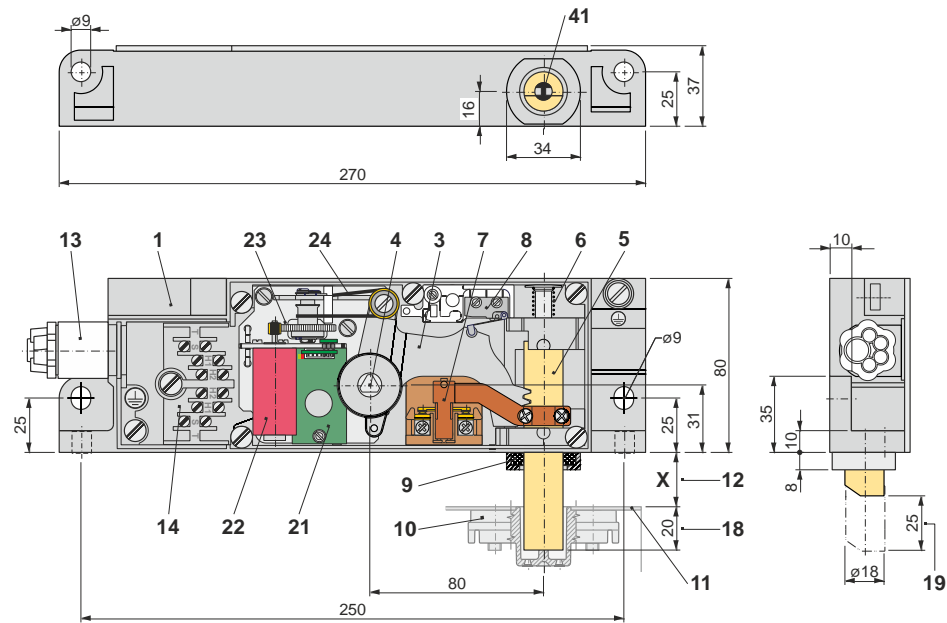

- | | | | |
|----|--|----|---|
| 1 | housing | 21 | motor electronics |
| 3 | tooth lever | 22 | electrical motor |
| 4 | tooth lever axis with triangle | 23 | gear |
| 5 | latch bolt (locking mechanism) | 24 | pull rope |
| 6 | return spring | 41 | faulty closure device (does not apply at DL1MO) |
| 7 | switching for locking mechanism | | |
| 8 | auxiliary switch (as option) | | |
| 9 | oiled felt ring with holder (from $X \geq 10$) | | |
| 10 | latch plate (does not apply at DL1MO) | | |
| 11 | door leaf | | |
| 12 | X-dimension according to customer specification | | |
| 13 | cable entry | | |
| 14 | connecting terminals | | |
| 18 | immersion depth of the latch bolt into the latch plate (nominal dimension) | | |
| 19 | bolt stroke | | |

3 Function and initial operation

3.1 Mode of operation

By applying a regulated DC voltage of 24 V for the terminals [22] of the motor electronics the latch bolt [5] is attracted and is held in its end position [LED lights up green].

The switch for locking mechanism [7] [positively driven contact] is thus opened and the safety circuit interrupted. The door is thus unlocked and can be opened.

The bolt can remain tightened as long as requested [100 % duty cycle].

The DC voltage is monitored by the motor electronics [21]. If a drop of the input voltage is detected, the motor current is switched off and the motor brake activated for a short time [red LED flickers]. The latch bolt [5] drops down damped into the latch plate [10], the switch for locking mechanism [7] is closed and the lift car can drive on.

3.2 Initial operation

The following points must be observed during assembly:

- intended use, permissible installation position and environmental conditions
- correct X-dimension [12]
- for the closing ability suitable bevel of the latch bolt
- sufficiently dimensioned fixation
- emergency release [4] accessible (opening with diameter 14 mm)
- suitable latch plate [10] for the DLF1MO with faulty closure device e.g. type BE or BS-V
- sufficiently large opening for the latch bolt [5]
- latch bolt [5] and emergency release [4] + [23] smooth

3.3 Settings

Latch bolt [5] and latch plate [10]:

The distance between the attracted bolt [5] and the latch plate [10] should be 5 mm.

3.4 Control

It must be ensured that the motor electronics are only supplied with voltage when the car is in the corresponding unlocking zone.

The motor can be supplied with voltage as long as requested (100 % duty cycle). The voltage of the motor electronics may be switched off after opening the door in normal operation only when the door has been closed again and the latch bolt can freely plunge into the latch plate or bore hole.

Only then it will be ensured that the engine brake that operates only a few seconds after the voltage has been switched off, makes the bolt drop in a damped way.

3.5 Closing ability

If the latch bolt [5] drops down e.g. due to a power failure at open door, it must still be possible to close the door. Where appropriate please provide a slight bevel at the door edge [11].

4 Maintenance

If the locks are installed correctly, maintenance is generally not required. We recommend an annual inspection at harsh operating conditions:

- tighten fastening screws
- check smooth running of the bolts [5] and the emergency release [4] + [23]
- check adjustment of bolt [5] to latch plate [10] (centering, 5 mm distance when attracted)
- remove rough contamination

5 Electrical connection

5.1 Connection plan

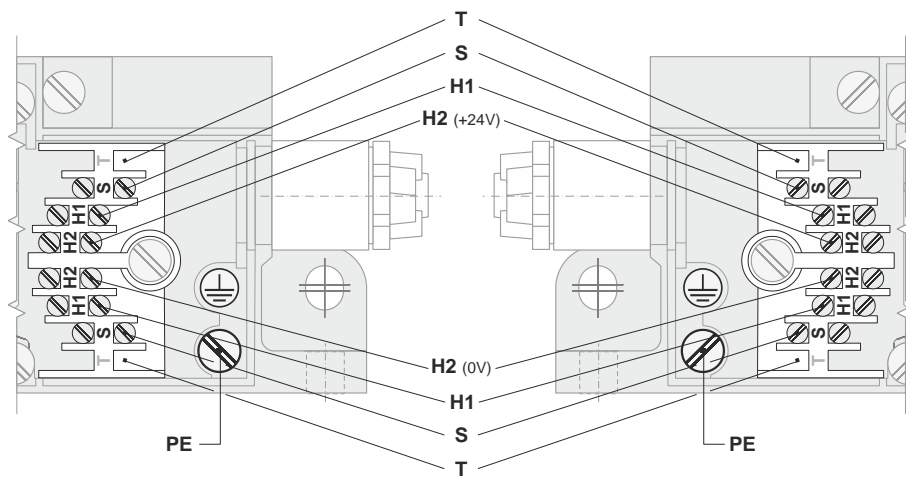

H1	connection for auxiliary switch
H2 (+24V)	connection for motor drive
H2 (0V)	connection for motor drive
PE	earthing connection
S	connection switch for locking mechanism
T	not used

6 Technical information

6.1 Operating directions

-L (latch bolt left)

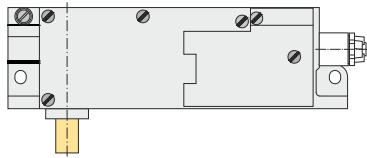

-R (latch bolt right)

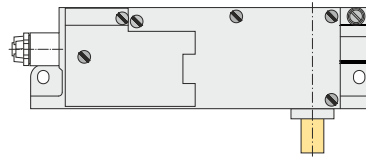

6.2 Customary positions

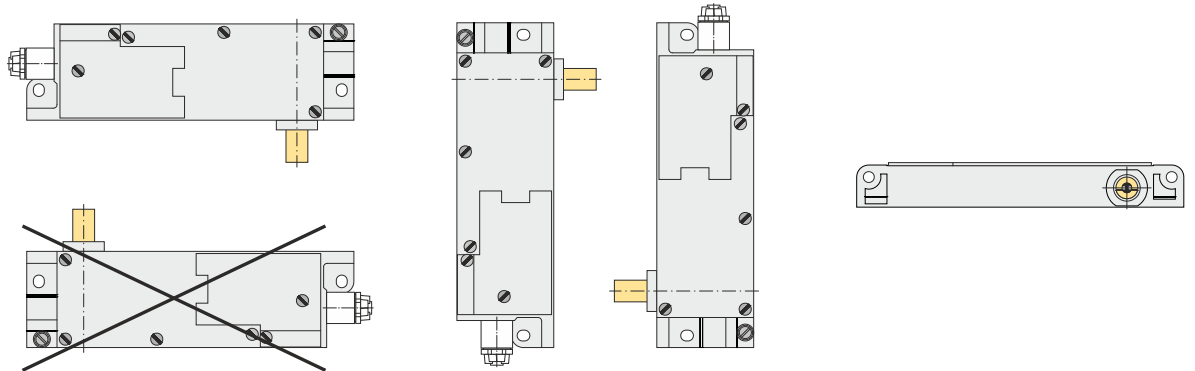

6.3 Technical data

norm	EN 81-20, EN 81-50, EN 81-21, EN 60947-5-1
certificates	type approval certificate: EU-DL 808-2 (DLF1MO) and EU-DL 807-2 (DL1MO)
switching capacity:	<p>switch for locking mechanism AC-15: $U_e = 230\text{ V}$ $I_e = 2\text{ A}$ DC-13: $U_e = 200\text{ V}$ $I_e = 2\text{ A}$</p> <p>auxiliary switch .90/01 AC: $U_e = 250\text{ V}$ $I_e = 6\text{ A}$ EN 61058 DC: $U_e = 200\text{ V}$ $I_e = 0.25\text{ (0.1) A}$ DC: $U_e = 60\text{ V}$ $I_e = 1.0\text{ (0.5) A}$ DC: $U_e = 24\text{ V}$ $I_e = 3.0\text{ (2.0) A}$</p>
short-circuit capacity	T 10 A F 16 A
contact material	fine silver
motor drive of the latch bolt:	
operating voltage	24 V DC (-10 % / +25 %)
pull-in current / time (typical)	0.8 A / < 0.5 s
holding current	0.15 A
connection	by screw terminal max. 2.5 mm ² cable entry $\varnothing = 23\text{ mm}$ with rubber grommet
level of protection	IP40
ambient air temperature	-10 °C up to +45 °C (special version up to -30°C)

7 Fault correction

7.1 Diagnosis at disruption in operation

Disruption	Status LED		Possible cause	Measure
	red	green		
bolt does not attract	off	off	no voltage or reverse polarity	check input voltage and polarity
	on	off	voltage too low	check input voltage, regulated 24 V DC +/-10 % necessary
	on	on	inappropriate voltage / too low	
attracted bolt sometimes drops down and then retracts			short voltage drop	Determine the cause for voltage drops and stop it. Check switch, contacts, power supply unit, control, wiring and other consumer-loads.
door interlock makes one or several bashing sounds when reaching the end position			Bolts were not dropped down completely, e.g. in faulty closure position. The fixed sequence does not comply, the bolt reaches the end position too soon, the motor continues to rotate and exceeds its breakdown torque.	Normal sequence if the bolt is attracted out of the faulty closure position. If possible ensure that only a completely dropped down bolt is attracted.
door interlock makes bashing sounds for approx. 30 seconds when attracting, does not reach the end position	flashes with long interval	on	Bolt or mechanism blocks, motor exceeds its breakdown torque.	Check adjustment and smooth running, remove blockade.

Notes:



Hans & Jos. Kronenberg GmbH

Kurt-Schumacher-Straße 1 | D-51427 Bergisch Gladbach
T: +49 2204 / 207-0 | E: info@kronenberg-gmbh.de

