

dargestellt / shown:
DLF1-WV - L - X15 - CHR (u) .10S



Merkmale

Allgemein:

- **Metallgehäuse** mit hoher Stabilität
- **geräuscharm** durch Aufsetzpuffer in beiden Richtungen
- **wartungsfrei** durch **Dauerschmierung** mit hochwertigen Schmierstoffen (bis zu -30 °C)
- geölter **Filzring** am Riegelbolzen zur Schmierung sowie zur Abdichtung gegen Schmutz und Staub (bei X-Maß ≥ 10 mm)
- zwangsläufige **Fehlschließesicherung** beim DLF1-WV für den Einsatz in Personenaufzügen
- Kontakte mit **massiver Feinsilberauflage** für eine zuverlässige Funktion, auch bei niedrigen Spannungen und Strömen
- **Hilfsschalter** als Öffner und/oder Schließer mit zwei galvanisch getrennten Kontakten möglich
- umfangreiches Zubehörprogramm

Besonderheiten:

- **Wasserschutz (IP54)** bei vertikaler Einbaulage in der Türzarge (-WV)
- **Metalldeckel** mit Gummidichtung statt Klarsichtdeckel
- **verchromter Riegelbolzen** für besseren Oxidationsschutz
- **Klemmenblock** mit allen elektrischen Anschlüssen
- Anschluss für **Bowdenzug** oder Seilzug zur Betätigung oder Entriegelung verfügbar, z. B.
 - Anwendungsfall 1: Entriegelung von der Schachtgrubenleiter (< 1,80 m nach EN 81-20)
 - Anwendungsfall 2: versetzter Notentriegelungsdreikant (< 2 m nach EN 81-20)
 - Anwendungsfall 3: Betätigung über Bowdenzug als Alternative zur Zugstange

features

general:

- **metal housing** with high stability
- **silent** due to buffers in both directions
- **maintenance-free** by **permanent lubrication** with high quality lubricants (up to -30 °C)
- oiled **felt ring** at latch bolt for lubrication as well as for sealing against dirt and dust (at X-dimension ≥ 10 mm)
- constrained **faulty closure** at DLF1-WV for use in passenger lifts
- contacts with **solid fine silver plating** for a reliable function even at low voltages and currents
- **auxiliary switch** as normally closed contact and/or normally open contact with two galvanically isolated contacts possible
- extensive range of accessories

special features:

- **waterprotection (IP54)** at vertical installation position in the door frame (-WV)
- **metal cover** with rubber seal instead of transparent cover
- **chromed latch bolt** for better oxidation protection
- **terminal block** with all electrical connections
- connection for **bowden cable** or cable pull for actuation or unlocking available, e.g.
 - application 1: unlocking from the pit ladder (< 1.80 m according to EN 81-20)
 - application 2: offset emergency release triangle (< 2 m according to EN 81-20)
 - application 3: actuation by bowden cable as alternative to pull rod

Bestellangaben / order information codes:

DLF1-WV - L - X... - CHR (u) .10S .2 .9/01 .-30°

<p>Grundgerät / basic type: _____</p> <p>DLF1-WV mit Fehlschließesicherung, Schutzart IP54, vertikale Gebrauchslage mit Kabeleinführung oben <i>with faulty closure device, level of protection IP54, vertical customary position with cable entry above</i></p> <p>DL1-WV ohne Fehlschließesicherung, Schutzart IP54, vertikaler Gebrauchslage mit Kabeleinführung oben <i>without faulty closure device, level of protection IP54, vertical customary position with cable entry above</i></p> <p>Ausführung / operating direction: _____</p> <p>R Rechtsausführung <i>right-hand operation</i></p> <p>L Linksausführung <i>left-hand operation</i></p> <p>Bolzenlänge / length of latch bolt: _____</p> <p>X... Maß (in mm) zwischen Türverriegelung und Türkante [X ≥ 5 mm bis 90 mm*] <i>dimension (in mm) between door interlock and door edge [X ≥ 5 mm to 90 mm*]</i></p> <p>Riegelbolzenmaterial / latch bolt material: _____</p> <p>CHR Messing verchromt <i>chromed brass</i></p> <p>V2A Edelstahl / <i>stainless steel</i></p> <p>Ausführung des Riegelbolzens / version of latch bolt: _____</p> <p>(u) Anschrägung unten (bodenseitig) <i>bevel below (base side)</i></p> <p>(o) Anschrägung oben (deckelseitig) <i>bevel above (cover side)</i></p> <p>(i) Anschrägung innen / <i>bevel inside</i></p> <p>(a) Anschrägung außen / <i>bevel outside</i></p> <p>(ANS0) keine Anschrägung bei DL1-WV <i>without bevel at DL1-WV</i></p> <p>(ANS...) Sonderanschlagung bei DL1-WV <i>special bevel at DL1-W</i></p> <p>Betätigungsart / kind of actuation: _____</p> <p>.10S über Zugstange, Sonderausführung mit Abdichtung <i>by pull rod, special version with sealing</i></p> <p>.14 über Bowdenzug / <i>by bowden cable</i></p> <p>.14S über Bowdenzug, Sonderausführung: flache Bauform, mit Abdichtung an der Gehäuseoberseite und runder Zugstange <i>by bowden cable, special version: flat design, with sealing at the top of the housing and round pull rod</i></p> <p>.20 aufgeschraubter Rollenhebel / <i>screwed on roller lever</i></p>	<p>Sonderausführung / special version: _____</p> <p>.-30° für den Einsatz bei Temperaturen bis -30 °C <i>for use at temperatures up to -30 °C</i></p> <p>Hilfsschalter / auxiliary switch:</p> <p>.9/01 Kontakt bei entriegelter Tür geschlossen <i>contact at unlocked door closed</i></p> <p>.9/02 2 Kontakte bei entriegelter Tür geschlossen <i>2 contacts at unlocked door closed</i></p> <p>.9/11 1 Kontakt bei entriegelter Tür geschlossen, 1 Kontakt bei entriegelter Tür offen <i>1 contact at unlocked door closed, 1 contact at unlocked door open</i></p> <p>.90/01 Kontakt bei entriegelter Tür geschlossen <i>contact at unlocked door closed</i></p> <p>Notentriegelung / emergency release:</p> <p>ohne Angabe bodenseitig / (stets vorhanden) without specification base side / (always existing)</p> <p>.1 bodenseitig und deckelseitig <i>base side an cover side</i></p> <p>.2 indirekt bodenseitig ohne Überwachung <i>indirect base side without monitoring</i></p> <p>.2/11**) indirekt bodenseitig mit integrierter Überwachung gemäß EN 81-21 <i>indirect base side with integrated monitoring according to EN 81-21</i></p> <p>.5***) bodenseitig und Anschluss für externe Notentriegelung über Seilzug oder Handbetätigung <i>base side and connection for external emergency release by cable pull or manual operation</i></p> <p>.14S****) bodenseitig und Anschluss für externe Notentriegelung über Bowdenzug, Sonderausführung: flache Bauform, mit Abdichtung an der Gehäuseoberseite und runder Zugstange <i>base side and connection for external emergency release by bowden cable, special version: flat design, with sealing at the top of the housing and round pull rod</i></p> <p><small>*) weitere auf Anfrage / others on request</small></p> <p><small>***) nur in Kombination mit Betätigung .10S only in combination with actuation .10S</small></p> <p><small>*****) nur in Kombination mit Betätigung .20 only in combination with actuation .20</small></p>
---	---

fett gekennzeichnete Parameter sind standardmäßig vorhanden / **parameters marked in bold print** are available as standard

Technische Daten:

Normen	EN 81-20, EN 81-50, EN 81-21, EN 60947-5-1
Zulassungen	Baumusterprüfbescheinigung: EU-DL 013 (DLF1-WV) und EU-DL 015 (DL1-WV) UK-DL 013 (DLF1-WV) und UK-DL 015 (DL1-WV)
Schaltleistung:	U _i = 250 V I _{th} = 10 A U _{imp} = 4 kV
Sperrmittelschalter	AC-15: U _e = 230 V I _e = 2 A DC-13: U _e = 200 V I _e = 2 A
Überwachungsschalter	AC-15: U _e = 230 V I _e = 2 A DC-13: U _e = 200 V I _e = 0,5 A
Hilfsschalter .9/...	AC-15: U _e = 230 V I _e = 2 A DC-13: U _e = 200 V I _e = 0,5 A
Hilfsschalter .90/01	AC: U _e = 250 V I _e = 6 A EN 61058 DC: U _e = 200 V I _e = 0,25 (0,1) A DC: U _e = 60 V I _e = 1,0 (0,5) A DC: U _e = 24 V I _e = 3,0 (2,0) A
Kurzschlussfestigkeit	T 10 A F 16 A
Kontaktwerkstoff	Feinsilber
Betätigung:	
Betätigungsmoment (typisch)	1,7 Nm am Rollenhebel
Betätigungskraft (typisch)	45 N an der Zugstange 20 N am Rollenhebel (bei 35 mm Hub)
max. Kraft im Ruhezustand	5 N an der Zugstange
Anschluss	über Schraubklemme max. 2,5 mm ² Kabeleinführung M25 mit Reduzierring und Kabelverschraubung M20x1,5
Schutzart	IP54, vertikale Gebrauchslage und Kabeleinführung oben
Umgebungstemperatur	-10 °C bis +65 °C (Sonderausführung bis -30 °C)
Gewicht	850 g bis 1100 g (je nach Ausführung)

technical data:

norms	EN 81-20, EN 81-50, EN 81-21, EN 60947-5-1
certificates	type approval certificate: EU-DL 013 (DLF1-WV) and EU-DL 015 (DL1-WV) UK-DL 013 (DLF1-WV) and UK-DL 015 (DL1-WV)
switching capacity:	U _i = 250 V I _{th} = 10 A U _{imp} = 4 kV
switch for locking mechanism	AC-15: U _e = 230 V I _e = 2 A DC-13: U _e = 200 V I _e = 2 A
monitoring switch	AC-15: U _e = 230 V I _e = 2 A DC-13: U _e = 200 V I _e = 0.5 A
auxiliary switch .9/...	AC-15: U _e = 230 V I _e = 2 A DC-13: U _e = 200 V I _e = 0.5 A
auxiliary switch .90/01	AC: U _e = 250 V I _e = 6 A EN 61058 DC: U _e = 200 V I _e = 0.25 (0.1) A DC: U _e = 60 V I _e = 1.0 (0.5) A DC: U _e = 24 V I _e = 3.0 (2.0) A
short-circuit capacity	T 10 A F 16 A
contact material	fine silver
actuation:	
actuation torque (typical)	1.7 Nm at the roller lever
actuation force (typical)	45 N at the pull rod 20 N at the roller lever (at 35 mm stroke)
max. force in non-operating state	5 N at the pull rod
connection	by screw terminal max. 2.5 mm ² cable entry M25 with reducing ring and cable gland M20x1.5
level of protection	IP54, vertical customary position and cable entry above
ambient air temperature	-10 °C up to +65 °C (special version up to -30 °C)
weight	850 g to 1100 g (according to version)

Geräteabmessungen / device dimensions:

dargestellt / shown:

DLF1-WV -R -X20 - CHR (u) .10S

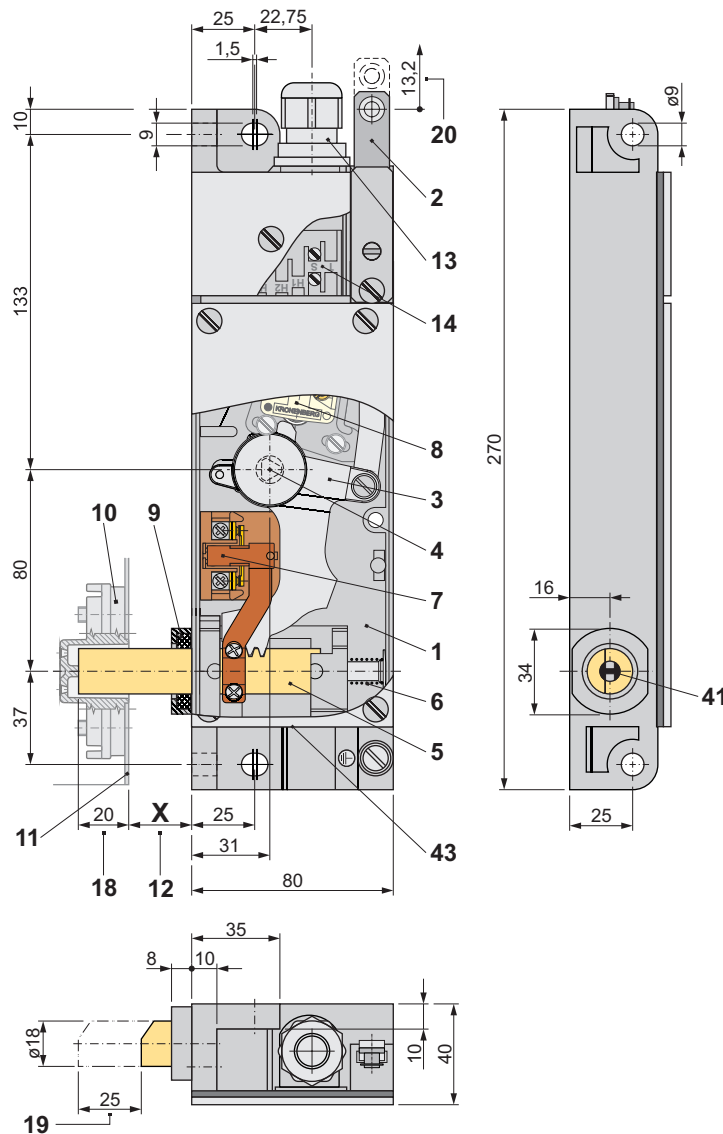

- 1 Gehäuse
- 2 Zugstange
- 3 Zahnhebel
- 4 Zahnhebelachse mit Dreikant (bodenseitig)
- 5 Riegelbolzen (Sperrmittel)
- 6 Rückdruckfeder
- 7 Sperrmittelschalter
- 8 Hilfsschalter (optional)
- 9 geölter Filzring mit Halter (ab X ≥ 10 mm)
- 10 Riegelbüchse (entfällt bei DL1-WV)
- 11 Türblatt / Türkante
- 12 X-Maß nach Kundenvorgabe
- 13 Kabeleinführung
- 14 Anschlussklemmen

- 18 Eintauchtiefe des Riegelbolzens in die Riegelbüchse (Nennmaß)
- 19 Bolzenhub
- 20 Betätigungsweg

- 41 Fehlschließesicherung (entfällt bei DL1-WV)
- 43 Ablauföffnung bei -WV

- 1 housing
- 2 pull rod
- 3 tooth lever
- 4 tooth lever axis with triangle (base side)
- 5 latch bolt (locking mechanism)
- 6 return spring
- 7 switch for locking mechanism
- 8 auxiliary switch (as option)
- 9 oiled felt ring with holder (from X ≥ 10 mm)
- 10 latch plate (does not apply at DL1-WV)
- 11 door leaf / door edge
- 12 X-dimension according to customer specification
- 13 cable entry
- 14 connecting terminals

- 18 immersion depth of the latch bolt into the latch plate (nominal dimension)
- 19 bolt stroke
- 20 actuating travel

- 41 faulty closure device (does not apply at DL1-WV)
- 43 drain opening at -WV

Gebrauchslagen / customary positions:

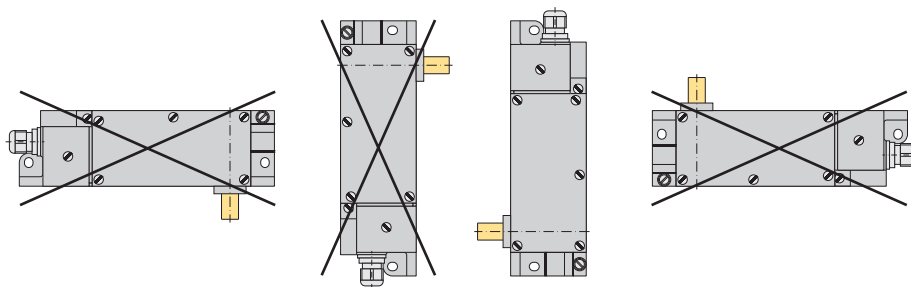

Ausführung / operating direction:

- L

linke Ausführung / left version

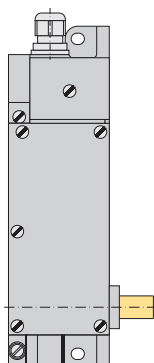

- R

rechte Ausführung / right version

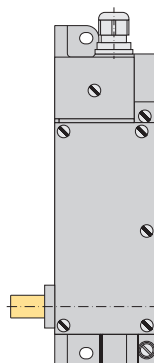

Standardzubehör / standard accessories:

- | | |
|-----|--|
| BE | Riegelbüchse bei DLF1-WV / latch plate at DLF1-WV |
| G60 | Gummirolle bei Betätigung mit .20
rubber roller at actuation by .20 |

Weiteres Zubehör finden Sie im Katalog „Zubehör Türverriegelungen“.
Please find further accessories in the catalogue “Accessories Door Interlocks”.

Ausführungen des Riegelbolzens / versions of the latch bolt:

Art der Riegelbolzenanschrägung / kind of the latch bolt bevel

Die Anschrägung ermöglicht das Schließen der Türe bei abgefallenem Riegelbolzen.
The bevel allows the closing of the door at dropped latch bolt.

(u), (o), (i), (a)
Anschrägung bei DLF
bevel at DLF

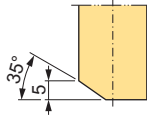

(u), (o), (i), (a)
Standardanschrägung bei DL ab $X \geq 10$ mm
standard bevel at DL from $X \geq 10$ mm

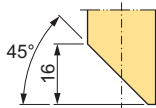

(ANS0)
keine Anschrägung bei DL
without bevel at DL



(ANS...)
Sonderanschrägungen bei DL / special bevels at DL

(ANS1/u), (ANS1/o), (ANS1/i), (ANS1/a)
ab $X \geq 14$ mm / from $X \geq 14$ mm

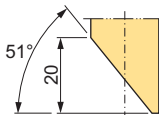

(ANS4/u), (ANS4/o), (ANS4/i), (ANS4/a)
ab $X \geq 5$ mm / from $X \geq 5$ mm

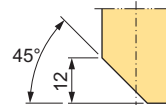

Lage der Riegelbolzenanschrägung (Prinzipdarstellung) / position of the latch bolt bevel (basic principle)

(u)
Anschrägung unten (bodenseitig)
für Drehtüren
bevel below (base side)
for swing doors

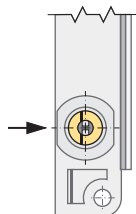

(o)
Anschrägung oben (deckelseitig)
für Drehtüren
bevel above (cover side)
for swing doors

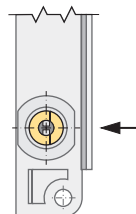

(i)
Anschrägung innen
für vertikale Rolltore
bevel inside
for vertical roller shutters

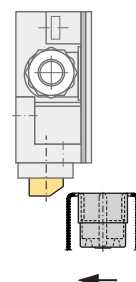
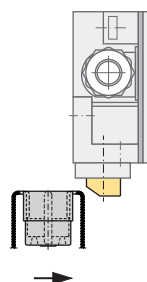
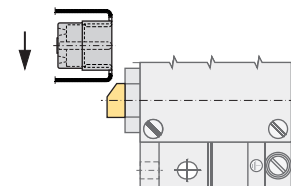

(a)
Anschrägung außen
für vertikale Rolltore
bevel outside
for vertical roller shutters

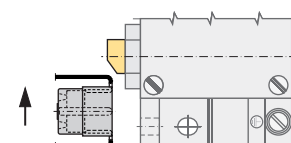

Betätigungsart / *kind of actuation:*

.10S

Betätigung über Zugstange, Sonderausführung mit Abdichtung / *actuation by pull rod, special version with sealing*

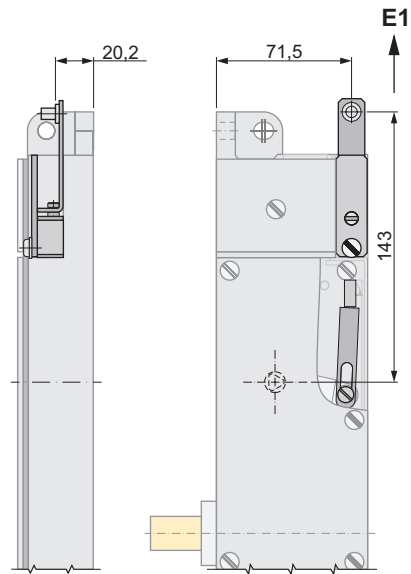

.14

Betätigung über Bowdenzug / *actuation by bowden cable*

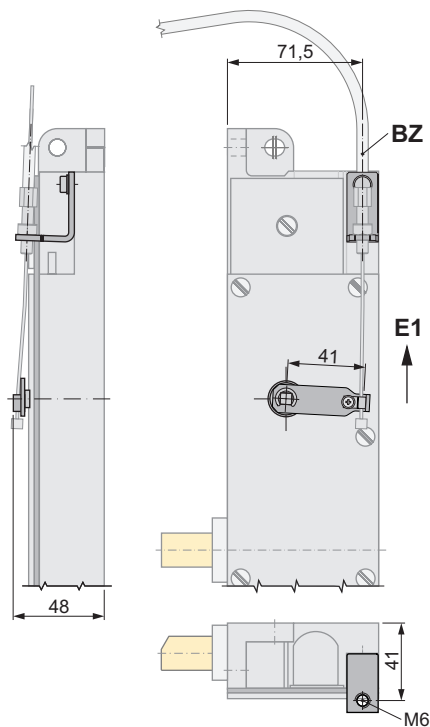

BZ Bowdenzug BZ...
(Zubehör - bitte separat bestellen)
bowden cable BZ...
(accessories - please order separately)

E1 Entriegelungsrichtung
unlocking direction

Betätigungsart / *kind of actuation:*

.14S

Betätigung über Bowdenzug, Sonderausführung: flache Bauform, mit Abdichtung an der Gehäuseoberseite und runder Zugstange
actuation by bowden cable, special version: flat design, with sealing at the top of the housing and round pull rod

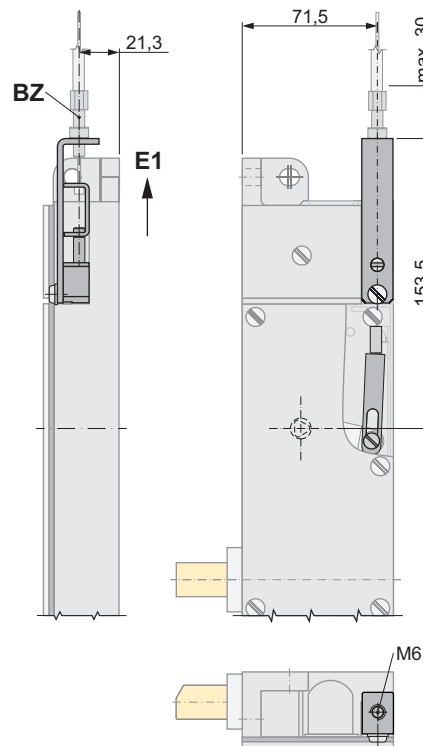

.20

Betätigung über aufgeschraubten Rollenhebel / *actuation by screwed on roller lever*

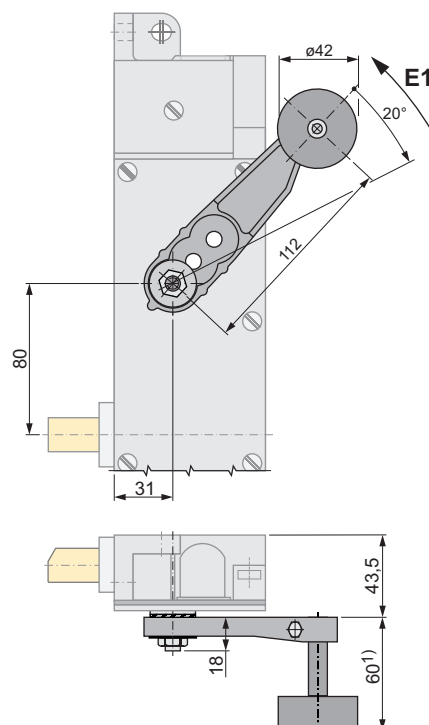

BZ Bowdenzug BZ...
(Zubehör - bitte separat bestellen)
*bowden cable BZ...
(accessories - please order separately)*

E1 Entriegelungsrichtung
unlocking direction

Notentriegelung / emergency release:

ohne Angabe / without specification

Notentriegelung bodenseitig an der Zahnhebelachse / emergency release base side at the tooth lever axis

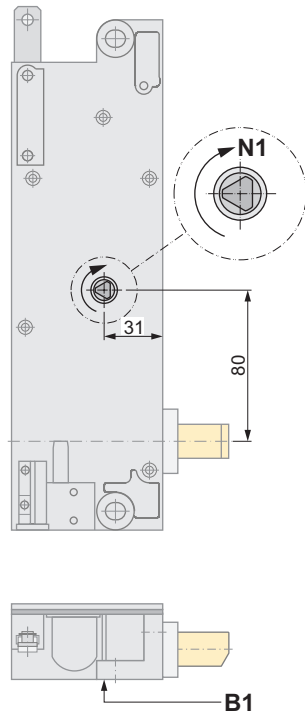

.1

Notentriegelung bodenseitig und deckelseitig an der Zahnhebelachse
emergency release base side and cover side at the tooth lever axis

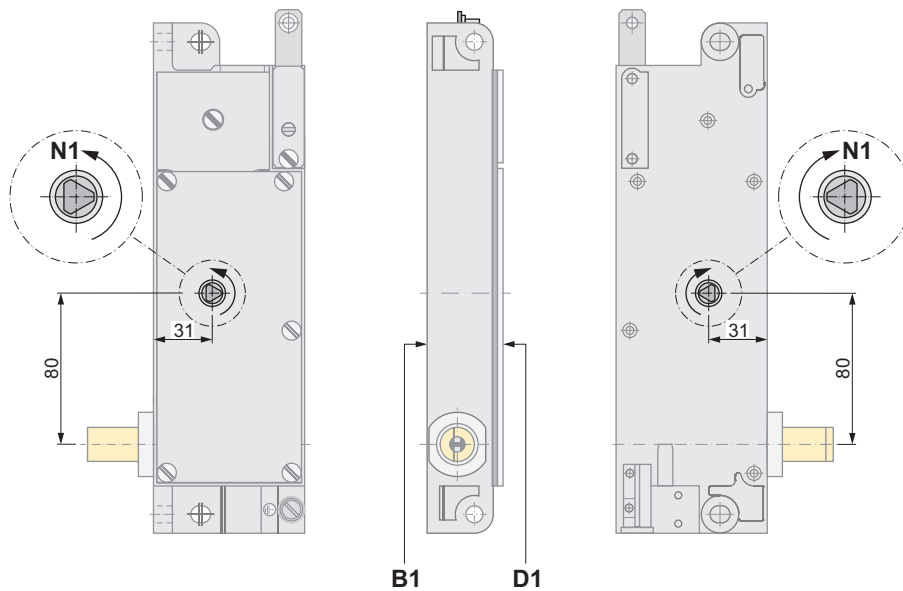

B1 bodenseitig / base side

D1 deckelseitig / cover side

N1 Entriegelungsrichtung Notentriegelung
unlocking direction emergency release

Notentriegelung / *emergency release:*

.2

Notentriegelung indirekt bodenseitig / *emergency release indirect base side*

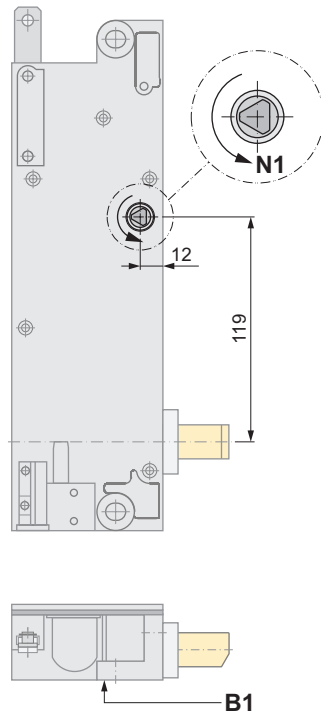

.2/11

Notentriegelung indirekt bodenseitig mit integrierter Überwachung gemäß EN 81-21
emergency release indirect base side with integrated monitoring according to EN 81-21

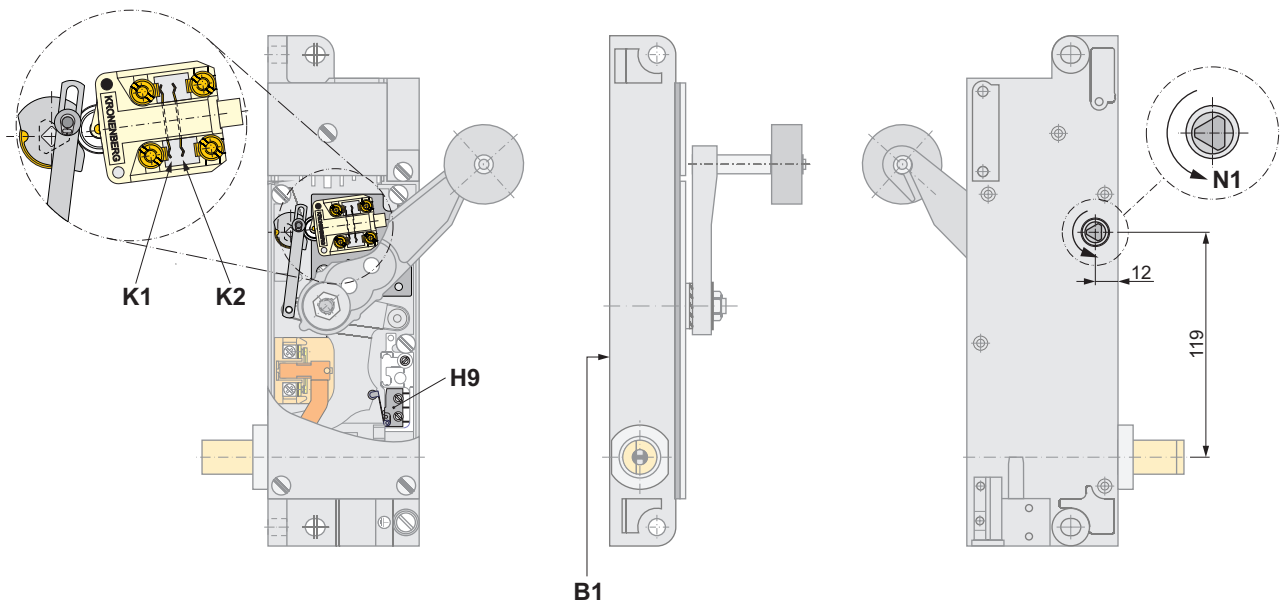

H9 optionaler Hilfsschalter
auxiliary switch as option

K1 Zwangsöffner / *positively driven normally closed contact*
K2 Schließerkontakt / *normally open contact*

B1 bodenseitig / *base side*

N1 Entriegelungsrichtung Notentriegelung
unlocking direction emergency release

Notentriegelung / emergency release:

.5

Notentriegelung bodenseitig und Anschluss für externe Notentriegelung über Seilzug oder Handbetätigung
emergency release base side and connection for external emergency release by cable pull or manual operation

.5 in Kombination mit Betätigung .10S (über Zugstange, Sonderausführung mit Abdichtung)

.5 in combination with actuation .10S (by pull rod, special version with sealing)

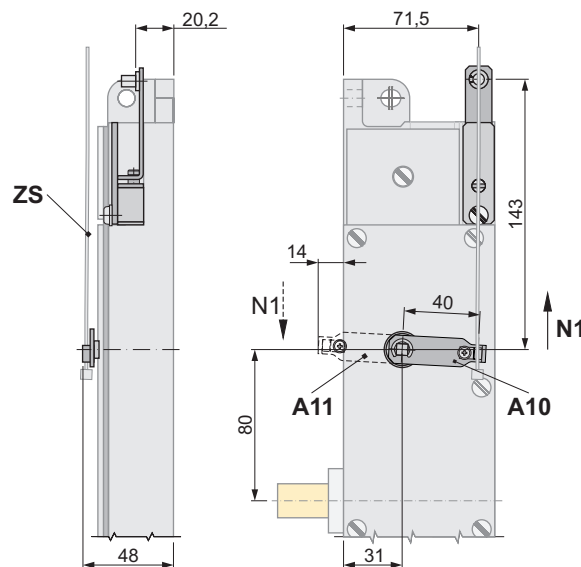

A10 Hebel / lever

A11 zum Ändern der Entriegelungsrichtung
Hebel umbauen, bitte Abmessungen beachten
to change the unlocking direction
convert the lever, please note the dimensions

N1 Entriegelungsrichtung Notentriegelung
unlocking direction emergency release

ZS Zugseil ZS-...
(Zubehör - bitte separat bestellen)
pull rope ZS-...
(accessories - please order separately)

Notentriegelung / *emergency release:*

.14S

Notentriegelung bodenseitig und Anschluss für externe Notentriegelung über Bowdenzug
Sonderausführung: flache Bauform, mit Abdichtung an der Gehäuseoberseite und runder Zugstange
*emergency release base side and connection for external emergency release by bowden cable
special version: flat design, with sealing at the top of the housing and round pull rod*

.14S in Kombination mit Betätigung .20 (aufgeschraubter Rollenhebel)

.14S in combination with actuation .20 (screwed on roller lever)

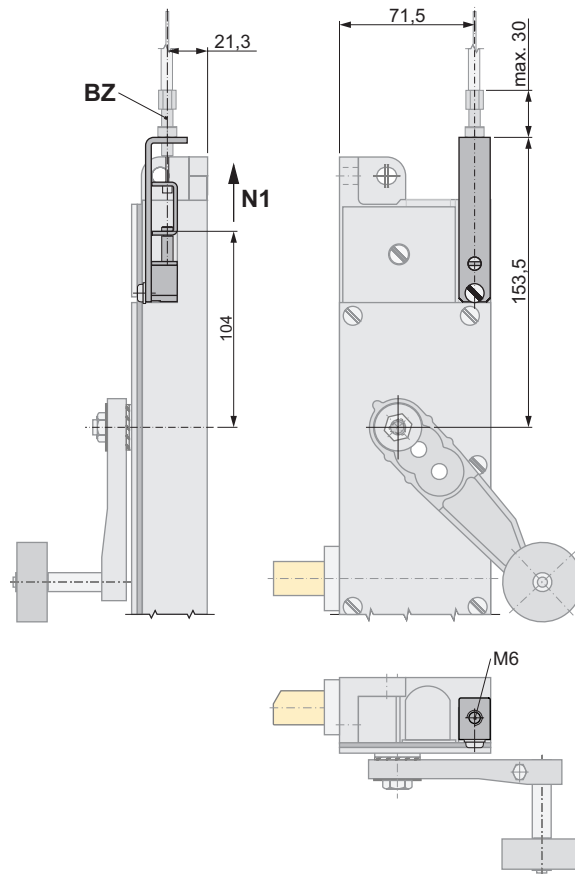

BZ Bowdenzug BZ...
(Zubehör - bitte separat bestellen)
bowden cable BZ...
(accessories - please order separately)

N1 Entriegelungsrichtung Notentriegelung
unlocking direction emergency release

Hilfsschalter / auxiliary switch:

.9/...



nicht kombinierbar mit
Notentriegelung .2/11
cannot be combined with
emergency release .2/11



.90/01

Kontakt bei entriegelter Tür geschlossen
contact at unlocked door closed



nur in Kombination mit
Notentriegelung .2/11
only in combination with
emergency release .2/11

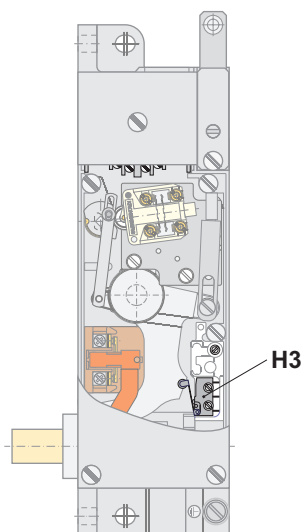

H3 Hilfsschalter .90/01 (Kontakt bei entriegelter Tür geschlossen)
auxiliary switch .90/01 (contact closed at unlocked door)